



Windlass Radio Remote



Installation and Operating Manual

Contents

Operation	
Remote Transmitter	3
Safety	3
Receiver	4
Installation and Maintenance	
Remote Transmitter	5
Receiver	6
Location & Mounting	6
Power Connections	7
Up/Down Switch Connections	7
Wiring Diagrams	9
Radio Interference	10
Specification	11

Coastline Technology Ltd.
17 Old Lane
Low Mill Village
Addingham
W.Yorks
LS29 0SA
UK

Tel: +44 (0) 1943 830399
Fax: +44 (0) 1943 831876
Email: info@coastlinetechnology.com
www: coastlinetechnology.com

Serial No. Frequency Date

17 February 2008

Operation

Remote Transmitter

To switch on the remote transmitter press down both buttons for 2 seconds. After 2 seconds the led will light up indicating that the unit is switched on. Release both buttons and the led will go out. The remote transmitter is now ready for use.

Press the blue (sea) button to lower the anchor, and press the yellow (sunshine) button to raise the anchor.

The remote transmitter automatically switches itself off after 10 minutes of inactivity.

The 2 second 'switch on' routine is a deliberate safety measure to prevent the unintentional operation of the windlass.

SAFETY

Great care should be taken with the windlass operation to ensure that anyone on the foredeck is well clear of the anchor chain and windlass mechanism when the windlass is operated.

Anyone using the windlass radio remote away from the foredeck must ensure that all foredeck crew are safe.

Battery replacement log

Date					
------	--	--	--	--	--

If you have any queries regarding your installation, please do not hesitate to contact us for assistance.

Receiver

We recommend that both the windlass itself and windlass remote receiver be isolated from the boat's batteries when not in use.

When first powered up the windlass remote receiver is in 'standby' mode and it does not become 'active' until it has received 10 consecutive correctly coded messages from the remote transmitter. This causes a brief (2 second) delay before the windlass is first operated. Thereafter the windlass will respond instantly to button presses on the remote transmitter.

The windlass remote receiver automatically reverts to standby mode after 10 minutes of inactivity.

Installation and Maintenance

Remote Transmitter

The remote transmitter uses 3 x 1.5V batteries and these are supplied already installed. They are standard AAA (MN2400, LR03, AM4) 1.5V Alkaline Manganese batteries with a shelf life in excess of 5 years and capacity for over 240 hours of continuous windlass operation. We recommend that the batteries be replaced every 5 years with high quality batteries such as those manufactured by Duracell or Varta.

To replace the batteries undo the four screws on the back of the unit and remove the cover. The batteries should be removed from the securing clips by levering them vertically away from the circuit board. Do **NOT** bend back the arms of the battery retaining clips. Replace with the new batteries, being sure to fit them the correct way round as indicated below.

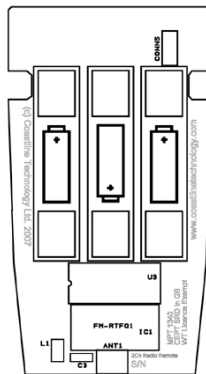

Replace the cover and tighten the screws. Do not over tighten the screws as this can cause permanent damage.

A wall holder is supplied which provides a convenient home for the transmitter when not in use.

Receiver

Location and Mounting

The windlass remote receiver can be mounted anywhere on the boat. Normally it is most convenient to mount it in the chain locker where it is close to the windlass and windlass solenoid, however in cases where a remote operating switch for the windlass is already provided elsewhere (e.g. in the cockpit), then this can also provide a straightforward installation.

The receiver should be mounted either horizontally or with the cable gland pointing downwards. It is best to mount the receiver away from large areas of metal as these can reduce the received radio signal strength.

It is also best to mount the receiver above the waterline and as high up as possible.

The mounting holes for the receiver can be found by lifting the wings on either side. It is not necessary to open the enclosure itself.

Although the receiver enclosure is highly water resistant it should not be mounted anywhere where it is likely to be submerged in water.

The cables provided are very high specification tinned marine grade (18 awg 15 Amp UL1007). They need to be protected from abrasion and we recommend the use of 'spiral wrap'.

2.5 metres of spiral wrap is provided and we recommend that this is applied once the installation has been tested.

Power Connections

The windlass remote receiver is powered from the boat's battery which can be either 12v or 24v.

The receiver can be connected to the supply to the windlass control system, and this is probably the most convenient assuming that the receiver is mounted in close proximity to the windlass itself.

The positive connection should be taken to the fused side of the windlass supply (see wiring diagrams):

Black - connect to boat's 0v supply

Red - connect to boat's +12v or +24v supply

Internal Fuses

Each pair of switch contacts is fused internally with a readily available 10 Amp 20mm fuse.

Up/Down Switch Connections

The windlass remote receiver includes two internal relay switches that can be used instead of, or in addition to standard foot switches or hard wired remotes.

Connection is very straightforward and the 3m cables supplied will be sufficient for most installations.

Yellow - Up (yellow = sunshine)

Blue - Down (blue = sea)

Boats with an 'Up only' windlass can still use the system, and need only use the 'Up' switch connections.

*****NOTE – Although highly rated, the relay switches should not be used for directly connecting power to the windlass itself. The Windlass Remote Receiver is used to operate a high powered solenoid and it is this that connects power to the windlass.**

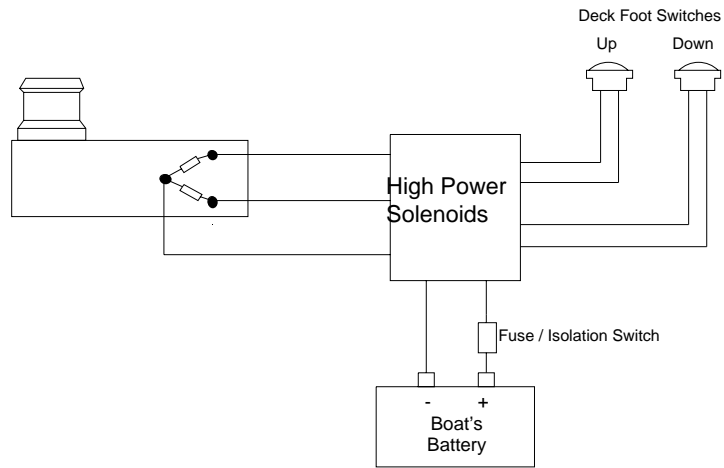

Typical installation using deck foot switches

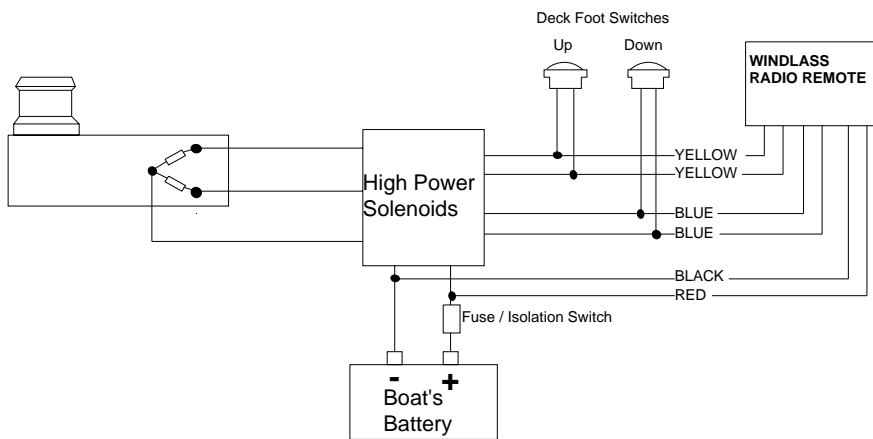

Installation with windlass radio remote connected in parallel with the existing foot switches

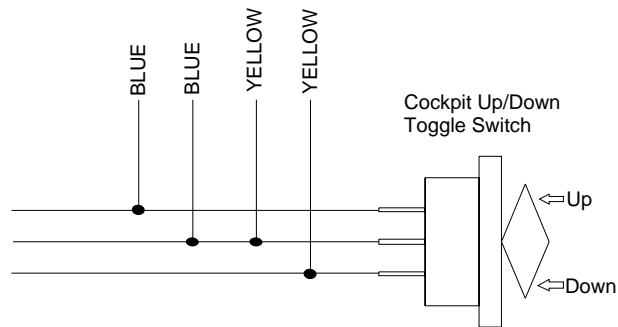

The Windlass Radio Remote can also be connected to work in parallel with cockpit mounted controls.

Radio Interference

Some windlass do generate very high levels of radio interference. This is particularly the case if the motor brushes are worn. In extreme cases this radio interference may interrupt signals from the remote transmitter. This effect shows itself by the windlass moving in slow jerks rather than continuously when the UP or DOWN button is pressed.

If this occurs then the solution is to fit a 1uF 200v capacitor across the windlass motor terminals. Most modern windlass will be supplied with an interference suppression capacitor fitted as standard.

Two suitable interference suppression capacitors are provided. The following diagram shows how these are fitted to both two and three terminal windlass.

These can be mounted either way round and will have no adverse effect on windlass operation. We recommend that these be fitted as part of the installation as they can only benefit the operation of the windlass radio remote and any other radio equipment that you have on board.

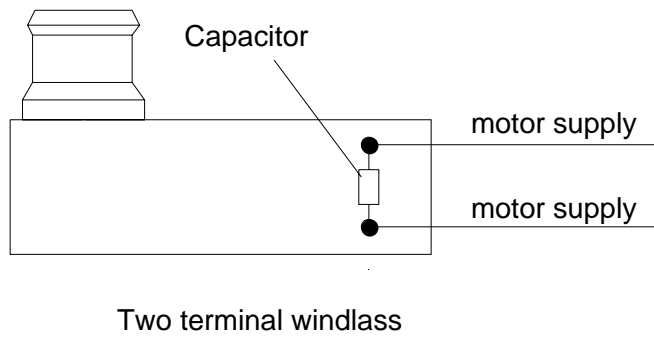
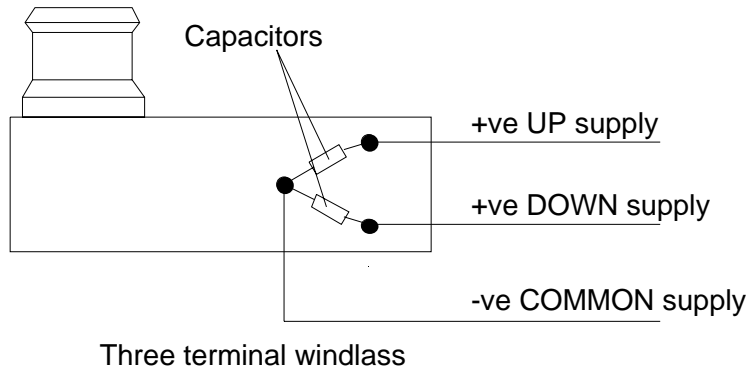

Specification

Transmitter

Size	60 x 140 x 30mm (approx)
Weight	130g (4.5oz)
Enclosure	ABS, Waterproof (IP65) Circuit board is protected with 'AquaStop' for additional protection against moisture and humidity.
Batteries	3 x AAA (MN2400, LR03, AM4) 1.5V Alkaline Manganese.
Current	Standby 0.5mA Transmitting 4mA
Frequency	433MHz (UK, Europe), 315MHz (US, Japan) MPT 1340 (UK) licence exempt.
RF Power	5dBm
Antenna	Integral embedded antenna, gain -3dBi
Temp	-20°C to 54°C

Receiver

Size	118 x 89 x 50mm (approx)
Weight	200g (7oz) exc. cables
Enclosure	ABS, Water resistant Circuit board is protected with 'AquaStop' for additional protection against moisture and humidity.
Supply	10-30v dc
Current	Standby 15mA @12v, 17ma @ 24v Active 110mA @ 12v, 150mA @ 24v
Rx Freq.	433MHz (UK, Europe), 315MHz (US, Japan)
RF Sens.	-102dBm
Antenna	Integral embedded antenna, gain -3dBi
Temp	-20°C to 60°C

